

D11-625

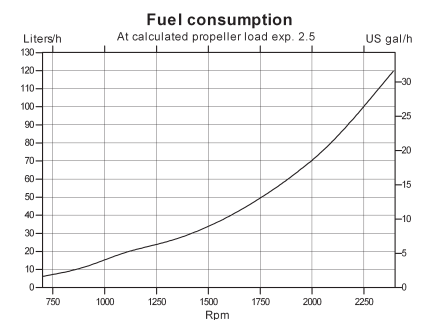

Technical Data

Engine designation	D11-625
No. of cylinders and configuration	in-line 6
Method of operation	4-stroke, direct-injected, turbocharged diesel engine with aftercooler
Bore/stroke, mm (in.)	123/152 (4.84/5.98)
Displacement, l (in ³)	10.84 (661.3)
Compression ratio	16.5:1
Dry weight bobtail, kg (lb)	1145 (2524)
Crankshaft power, kW (hp) @ 2400 rpm	460 (626)
Max. torque, Nm (lbf.ft) @ 1900 rpm	2161 (1594)
Emission compliance	IMO NOx, EU RCD, US EPA Tier 3
Rating	R4*
Recommended fuel to conform to	ASTM-D975 1-D & 2-D, EN 590 or JIS KK 2204
Specific fuel consumption, g/kWh (lb/hph) @ 2400rpm	219 (0.355)
Flywheel housing/SAE size	11.5"/SAE 2
Technical data according to ISO 8665. With fuel having an LHV of 42700 kJ/kg and density of 840 g/liter at 15 °C (60 °F). Merchant fuel may differ from this specification which will influence engine power output and fuel consumption.	
*RATING 4. For light planing craft in commercial operation	

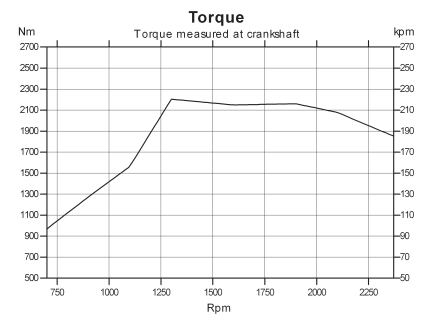
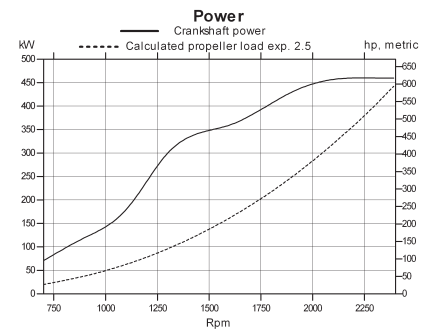

VOLVO PENTA

D11-625

Technical description:

Engine and block

- Cylinder block made of cast iron
- One-piece cast-iron cylinder head
- Ladder frame fitted to engine block
- Replaceable wet cylinder liners and valve seats/guides
- Drop forged crankshaft with induction hardened bearing surfaces and fillets with seven main bearings
- Four-valve-per-cylinder layout with overhead camshaft and center position of unit injectors
- Each cylinder features cross-flow inlet and exhaust ducts
- Gallery oil-cooled cast aluminum alloy pistons with three piston rings
- Rear-end transmission

Engine mounting

- Flexible engine mounting (option)

Lubrication system

- Integrated oil cooler in cylinder block
- Symmetrically positioned twin full flow oil filter of spin-on type and by-pass filter

Fuel system

- Electronic high pressure unit injectors
- Gear-driven fuel pump and injection timing
- Electronically controlled central processing system (EMS – Engine Management System)
- Single fine fuel filter of spin-on type, with water separator and water alarm

Air inlet and exhaust system

- Mid-positioned twin entry turbocharger with aftercooler
- Air filter with replaceable inserts
- Wet exhaust elbow (option)
- Loss of sea water alarm

Cooling system

- Seawater-cooled tubular heat exchanger
- Coolant system prepared for hot water outlet

- Easily accessible seawater impeller pump in rear end

Electrical system

- 24V with extra 12V/115A or 24V/80A alternator

Instruments/controls

- Complete instrumentation/display packages, including e-key, the electronic key from Volvo Penta.
- EVC monitoring panels for single or twin installations
- Electronic shift and throttle
- Plug-in connectors
- EVC system color display (option)

Reverse gear

- ZF305-3A-E, ZF325IV-E, electronically shifted
- Low speed available as option

Dimensions D11-625 with ZF305-3A-E

Not for installation

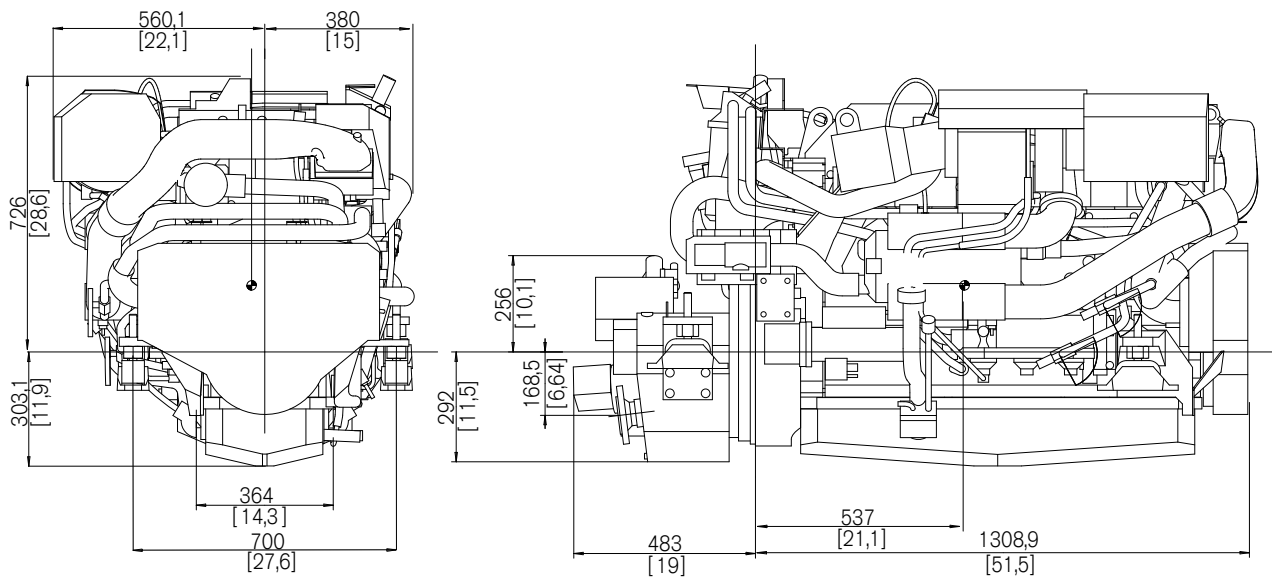

More information

Contact your nearest Volvo Penta dealer for more information about Volvo Penta engines and optional equipment/accessories or go to www.volvopenta.com



IOS



Android

Download the Volvo Penta dealer locator App for your iPhone or Android

VOLVO PENTA

AB Volvo Penta

SE-405 08 Göteborg, Sweden
www.volvopenta.com

Not all models, standard equipment and accessories are available in all countries. All specifications are subject to change without notice. The engine illustrated may not be entirely identical to production standard engines.